

NPV Undirectional Valve

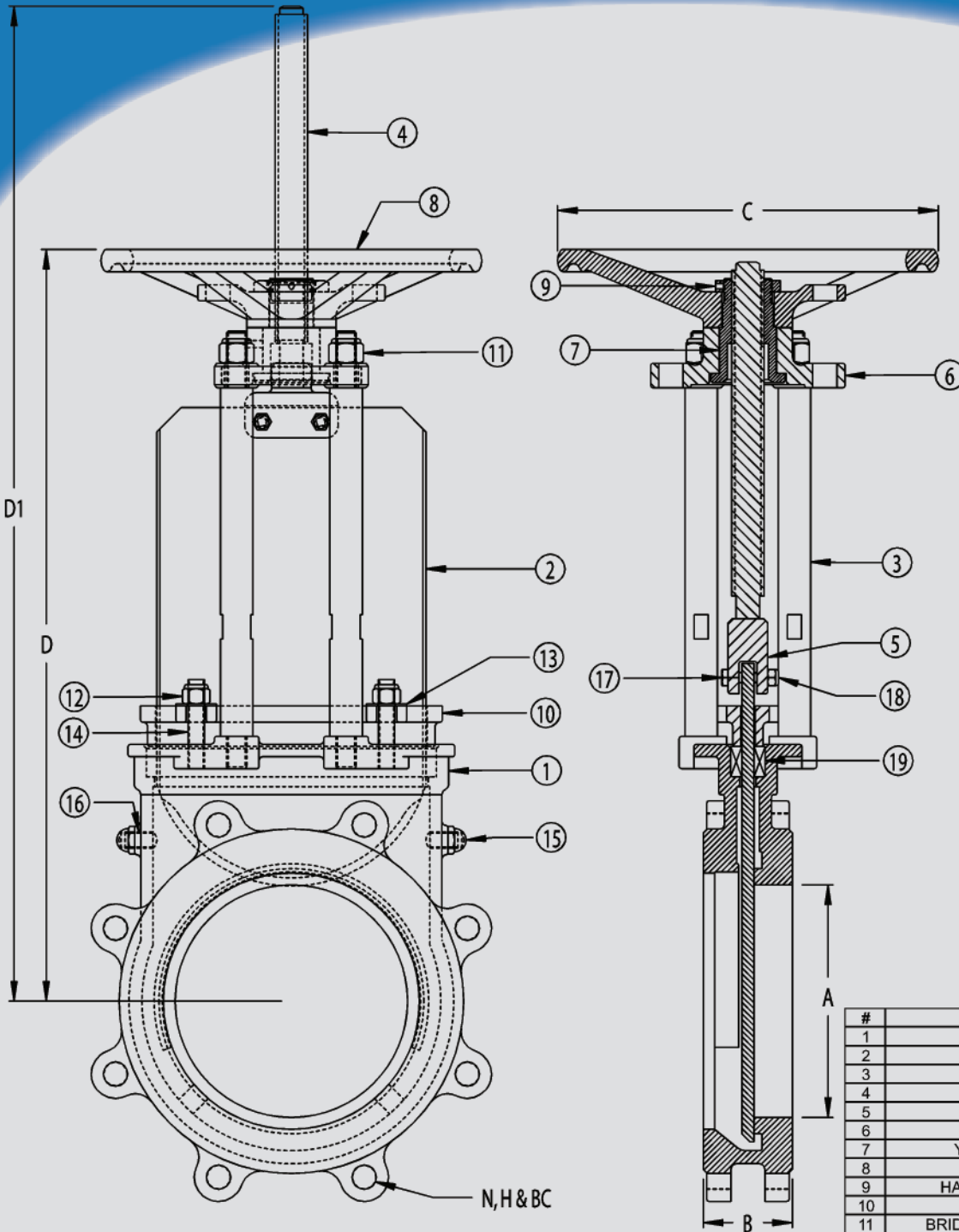

#	PART NAME	MATERIAL
1	BODY	CG8M (317 S.S.)
2	GATE	316L S.S.
3	STANCHION	303 S.S.
4	STEM	303 S.S.
5	COUPLING	CG8M (317 S.S.)
6	BRIDGE	ALUMINUM 356
7	YOKE SLEEVE	660 BRONZE
8	HANDWHEEL	ALUMINUM
9	HANDWHEEL NUT	NAVY BRASS
10	GLAND	CG8M (317 S.S.)
11	BRIDGE NYLOCK NUT	18.8 S.S.
12	GLAND NYLOCK NUT	18.8 S.S.
13	GLAND WASHER	18.8 S.S.
14	GLAND STUD	18.8 S.S.
15	ACORN NUT	BRASS
16	ALIGNMENT STUD	18.8 S.S.
17	COUPLING BOLT	18.8 S.S.
18	COUPLING NYLOCK NUT	18.8 S.S.
19	PACKING	TEFLON

	2"	3"	4"	5"	6"	8"	10"	12"	14"	16"	18"	20"	24"	30"	36"
A	2"	3"	3 3/4"	4 7/8"	5 3/4"	7 5/8"	9 1/2"	11 1/8"	13 3/16"	15 35/64"	17 7/16"	19 11/32"	23"	28 5/16"	33 1/2"
B	1 7/8"	2"	2"	2 1/4"	2 1/4"	2 3/4"	2 3/4"	3"	3"	3 1/2"	3 1/2"	4 1/2"	4 1/2"	4 1/2"	5"
N(HOLES)	4	4	8	8	8	8	12	12	12	16	16	20	20	28	32
H(TAP)	5/8" - 11	5/8" - 11	5/8" - 11	3/4" - 10	3/4" - 10	3/4" - 10	7/8" - 9	7/8" - 9	1" - 8	1" - 8	1 1/8" - 7	1 1/8" - 7	1 1/4" - 7	1 1/4" - 7	1 1/2" - 7
BC	4 3/4"	6"	7 1/2"	8 1/2"	9 1/2"	11 3/4"	14 1/4"	17"	18 3/4"	21 1/4"	22 3/4"	25"	29 1/2"	36"	42 3/4"
C	7 1/2"	7 1/2"	7 1/2"	9"	9"	11 3/4"	11 3/4"	15 3/4"	15 3/4"	15 3/4"	20"	20"	23 5/8"	26 3/4"	31 1/2"
D	11 5/8"	13 1/2"	15"	17"	18 1/4"	23"	28"	31 7/8"	36 7/8"	44 1/2"	48 1/4"	53 7/8"	61"	72 1/2"	90"
D1	14 3/4"	17 1/8"	19"	22 3/8"	23 1/2"	30 5/8"	37 1/2"	43 7/8"	50 5/8"	60 1/2"	66"	73 5/8"	84 3/4"	106"	129"
WGT.	21	27	32	38	48	86	120	164	228	390	438	630	960	1390	1820