

# NPV Bidirectional Valve

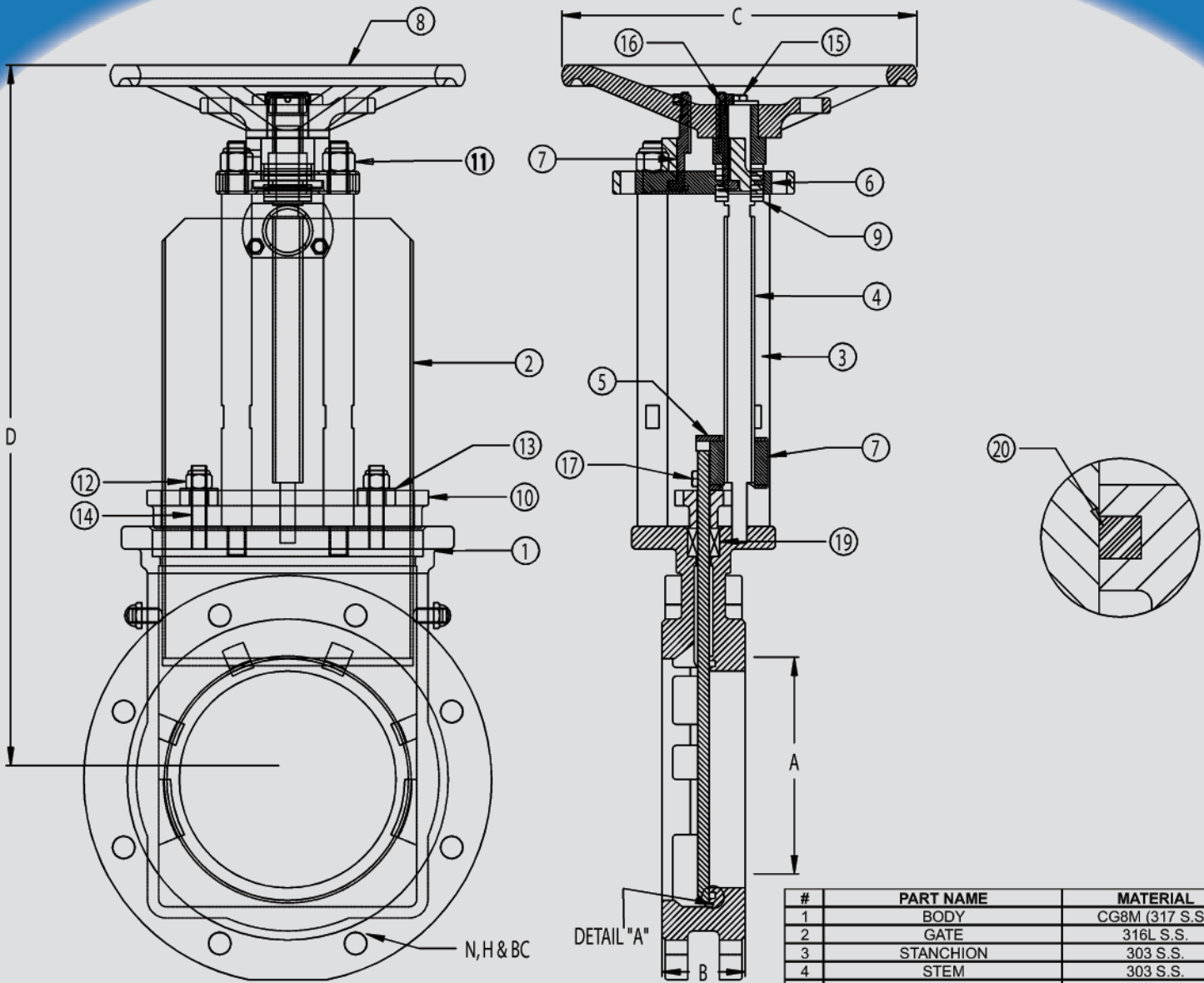

#	PART NAME	MATERIAL
1	BODY	CG8M (317 S.S.)
2	GATE	316L S.S.
3	STANCHION	303 S.S.
4	STEM	303 S.S.
5	COUPLING	CG8M (317 S.S.)
6	BRIDGE	303 S.S.
7	STEM NUT	660 BRONZE
8	HANDWHEEL	ALUMINUM
9	BEARINGS	N/A
10	GLAND	CG8M (317 S.S.)
11	BRIDGE NYLOCK NUT	18.8 S.S.
12	GLAND NYLOCK NUT	18.8 S.S.
13	GLAND WASHER	18.8 S.S.
14	GLAND STUD	18.8 S.S.
15	HANDWHEEL BOLT	18.8 S.S.
16	WASHER	18.8 S.S.
17	COUPLING BOLT	18.8 S.S.
18	COUPLING NYLOCK NUT	18.8 S.S.
19	PACKING	TEFLON
20	O-RING	VITON

	2"	3"	4"	5"	6"	8"	10"	12"	14"	16"	18"	20"	24"	30"	36"
<b>A</b>	2"	3"	3 3/4"	4 7/8"	5 3/4"	7 5/8"	9 1/2"	11 1/8"	13 3/16"	15 35/64"	17 7/16"	19 11/32"	23"	28 5/16"	33 1/2"
<b>B</b>	1 7/8"	2"	2"	2 1/4"	2 1/4"	2 3/4"	2 3/4"	3"	3"	3 1/2"	3 1/2"	4 1/2"	4 1/2"	4 1/2"	5"
<b>N(HOLES)</b>	4	4	8	8	8	8	12	12	12	16	16	20	20	28	32
<b>H(TAP)</b>	5/8" - 11	5/8" - 11	5/8" - 11	3/4" - 10	3/4" - 10	3/4" - 10	7/8" - 9	7/8" - 9	1" - 8	1" - 8	1 1/8" - 7	1 1/8" - 7	1 1/4" - 7	1 1/4" - 7	1 1/2" - 7
<b>BC</b>	4 3/4"	6"	7 1/2"	8 1/2"	9 1/2"	11 3/4"	14 1/4"	17"	18 3/4"	21 1/4"	22 3/4"	25"	29 1/2"	36"	42 3/4"
<b>C</b>	7 1/2"	7 1/2"	7 1/2"	9"	9"	11 3/4"	11 3/4"	15 3/4"	15 3/4"	15 3/4"	20"	20"	23 5/8"	26 3/4"	31 1/2"
<b>D</b>	11 5/8"	13 1/2"	15"	17"	18 1/4"	23"	28"	31 7/8"	36 7/8"	44 1/2"	48 1/4"	53 7/8"	61"	72 1/2"	90"